

# Inserter Mailing Systems



*Relay® 8000 Folder Inserter*

to mid volume mailers to bring you increased speed, flexibility and precision. This inserter folds, inserts and seals up to 62,500 a month with throughput of 4,000 envelopes per hour. We know your customers' privacy and security is critical. The optional file control is a proven Pitney Bowes technology version of file-based processing that goes beyond traditional OMR or 1D and 2D barcodes scanning by using a Reference File to control the folding and inserting process. You can track not only what pages are being folded and inserted, but also which specific pages are intended for each individual customer, giving you the capability to recreate a mailing event at a personalized recipient level. Achieve greater levels of accuracy, security and speed with the Relay 5000 inserting system.

## **RELAY® 7000 MID TO HIGH VOLUME TABLETOP FOLDER INSERTER:**

The Relay 7000 can fold, insert and seal up to 5,400 pieces per hour with a monthly throughput of up to 120,000 envelopes per month. It brings a standard load-on-the-fly high capacity envelope feeder which can hold up to 500 envelopes. Letters and flats can be processed in the same job with counts of up to 25 pages inserted into flat envelopes. Higher volume mailers can add up to 2 high capacity sheet feeders, each with a capacity of up to 2,000 pages. The Relay 7000's optional file control integrity is the proven Pitney Bowes file-based processing technology that goes beyond traditional OMR or 1D and 2D barcodes scanning by using a Reference File to control the folding and inserting process. You can track not only what pages are being folded and inserted, but also which specific pages are intended for each individual customer.

## **RELAY® 8000 HIGH VOLUME TABLETOP FOLDER INSERTER:**

The Relay 8000 is our flagship tabletop folder inserter. Its enhanced chassis gives you monthly throughput of up to 200,000 envelopes per month. This inserting system can process letters and flats in the same mailing run with speeds of up to 5,400 envelopes per hour. You get peace of mind knowing your mail is completed accurately with a reliable system. Higher volume mailings are handled with ease by adding up to 2 optional high capacity sheet feeders, each with a capacity of up to 2,000 pages. The Relay 8000's optional file control integrity is the proven Pitney Bowes file-based processing technology that goes beyond traditional OMR or 1D and 2D barcode scanning by using a Reference File to control the folding and inserting process.

**CONTACT:** For details, visit [PitneyBowes.com](http://PitneyBowes.com).

## § QUADIENT

**CATEGORY:** Inserter Mailing Systems

**PRODUCT:** Document Systems

**COMPANY:** Quadient, 478 Wheelers Farms Rd., Milford, CT 06461. Phone: 800-636-7678.

**DS-40i:** The DS-40i allows offices and departmental organizations with daily folding and inserting applications to benefit



*Quadient DS-40i*

from the same advanced technology that provides the precision and reliability associated with large volume mailing systems. The DS-40i is designed to handle a monthly envelope inserting volume of 5,000. It has a simple and intuitive user interface enabling all personnel to operate the system without being trained and with no need for a dedicated operator. This automated system fits

perfectly on a desk and ensures users do not have to waste time and money to hand-fold and insert their day-to-day outgoing mailing, enabling on-demand inserting. The DS-40i has a simple hand-feeding option, which allows users to put the paper in its feeder every time a set of documents is read to be sent.



*Quadient DS-64i*

**DS-64i:** The compact design, intuitive 7" color touchscreen interface and overall ease-of-use of the DS-64i make it the ideal choice for any business environment. At speeds of up to 2,000 envelopes per hour/2,500 with performance package, the DS-64i folding inserting system has the technology needed to efficiently prepare your business mailings. It automates the processing of checks, multi-page invoices, letters, legal-size documents, inserts and business reply envelopes. The CIS reads a full range of barcodes and optical marks printed on your documents, allowing securely processing of variable page documents

**DS-77 iQ:** The DS-77 iQ folder inserter system is the ideal productivity tool for any office or mailroom environment, thanks to its unique low level noise and compact footprint. High Productivity: processing speed of up to 3,800 inserts per

# Inserting Mailing Systems



**Quadiant DS-77 iQ**

hour, high-capacity document feeders holding up to 725 sheets of 20 lb. paper, standard high-capacity vertical stacker holding up to 500 envelopes. High Mailing Application

**Flexibility and Support:** increased folding capacity; support for barcode reading in personalizing transactional and marketing mail. **New Standard in Ease of Use:** new graphical color touch screen designed for easy setup, semi-automatic envelope separation setup; automatic sealing liquid level detection and automated sealing capability. The DS-77 iQ can process a wide variety of mail pieces for direct marketing efforts, campaigns, invoicing, monthly statements and virtually any other application companies can or will do in the future.

**DS-85i:** Ideal for mail centers maintaining an outgoing speed of 4,000 filled envelopes per hour, the DS-85i provides enhanced ease-of-use, increasing customers' mailroom efficiency and productivity, while reducing postal costs. The DS-85i's unique full-color touch screen can be reversed to allow operation from any angle. Quadiant's "Load 'n Go" feature further simplifies the mailing process, as users need only to load documents and envelopes into the machine and then press the "Go" button. The DS-85i automatically adjusts settings, saving them to memory for instant recall during future mailings. In addition, the folder inserter's operation requires the use of only three buttons, allowing anyone to easily run the machine. Add an optional barcode reading solution to easily apply barcodes to existing documents to ensure each recipient receives their correct documents.

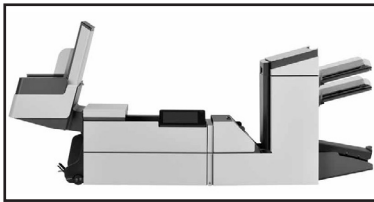

**Quadiant DS-85i**

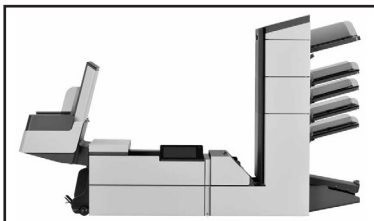

**Quadiant DS-95i**

**DS-95i:** The DS-95i is the ultimate mid-range solutions for your inserting needs. The completely new graphical user interface with full color icons walk the operator through set up in just three steps – and that's in manual mode! Remote Assistance provides your Quadiant customer service team with immediate access to your system over the internet to help maximize your productivity. DS-95i includes a color graphical user interface with super bright touch screen; Remote Assist – connect to your service tech over the internet; flexFeed® technology gives you the ability to handle any doc-

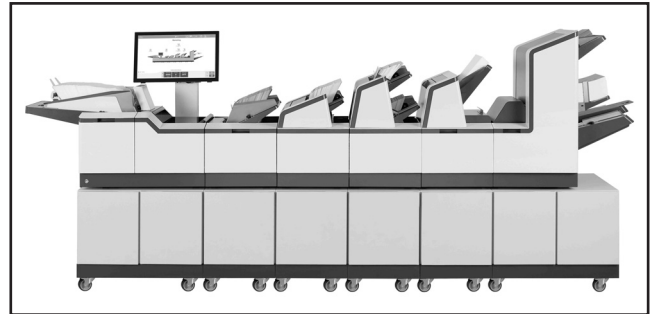

**Quadiant DS-180i**

ument size or paper type; With powerFold®, you can crisply and silently fold up to 10 pages in single fold and 8 pages in tri-fold; Add optional OMR, 1D or 2D Barcode or Optical Character Recognition to ensure each recipient gets their correct documents; Configurable from two to seven stations and totally upgradeable; High capacity carrier envelope hopper holds 500 envelopes with optional 1000 envelope capacity; High capacity document feeder holds 725 sheets; Versafeeder holds up to 500 BRE envelopes; Feeder linking allows for continuous document feeding of up to 3,125 sheets.

**DS-180i:** The DS-180i folding inserting systems makes operational excellence a reality for your mail processing needs. Its modular design supports the widest range of mailing applications – from direct mail campaigns to highly sensitive mailings such as medical billing, payroll and financial statements. The system uses Quadiant's proprietary and robust IMOS operating system and, as a result, has the features and technology to meet the demands of your business with ease. Due to its ability to handle a superior document packet thickness of 1/4", the DS-180i allows you to process a wide variety of mail for invoicing, monthly statements, marketing campaigns and virtually all of your organizations mail requirements. The system's large color graphic interface reaches new heights in user friendliness and workflow programming. Enhance the productivity of your mail center with the DS-180i Performance Package. It has earned the designation of "Performance Package" for its increased processing speed, envelope capacity, enhanced sealing capacity and productivity. The DS-180i can be customized to process your applications with up to 8 system modules and 17 feeders.

**DS-700 iQ:** The new standard in mail production, the DS-700 iQ is a powerful solution that has an advanced modular design that will grow with mailer needs. Quadiant engineers took a hard look at mail centers around the world and then designed this advanced folding and inserting system which can be customized to meet the workflow requirements of the widest range of mailing applications, including flats. The practical speed is up to 7,000 envelopes per hour and can handle monthly volumes up to 300,000. Users will find practical innovation everywhere you look. Powerful and intuitive, the DS-700 iQ has unlimited job memory; auto-setup, which eliminates hours of manual adjustments; a unique scanning module reads almost

## Inserter Mailing Systems

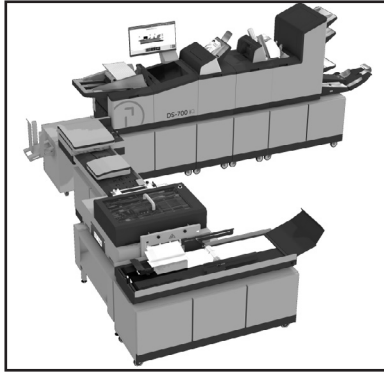

**Quadient DS-700 iQ**

any type of document coding; landscape insertion, offering higher speeds and lower envelope costs; and a 23" color touch screen. The DS-700 iQ meets the workflow demands of almost every mailing application – from direct marketing to highly sensitive mailings including medical billing and patient information, to payroll and personal financial statements. Our inline secure personalization module provides security and the ability to meet privacy compliance requirements. For marketers, it provides unprecedented personalization opportunities. The DS-700 iQ fully integrated direct impression envelope printing solution allows you to personalize envelopes as part of the mail assembly process. This eliminates the need for window envelopes and insures the privacy of your important customer information. Once the documents have been folded and inserted, the secure system prints the matched name and address on the closed face envelope. This process ensures integrity and security, allowing sensitive information to remain confidential.

**DS-1200 G5iQ:** The DS-1200 G5iQ is designed to operate at the highest practical speed – up to 12,000 envelopes per hour – and efficiency with numerous new design updates driven by customer and field engineer feedback. The new DS-1200 G5i streamlines the entire mailing process, from input to throughput to output. The DS-1200 G5iQ One-Touch document loading technology ensures document integrity and when combined with Quadient's IMOS operating system records movement of all documents through the system. The high-capacity sheet feeders, insert stations, envelope feeder, and updated vertical envelope output stacker enable users to maintain the highest level of operational productivity even for the most demanding mail processing job.

**MACH 9DS:** The Quadient MACH 9DS is an intelligent and dynamic inline color inkjet envelope printing system. More than just a printer, the MACH 9DS is a technology system that includes a fully automated, full color inkjet HP print engine, a heavy duty vacuum transport, a powerful Dell PC with Intel Core vPro processor and an intelligent software management sys-

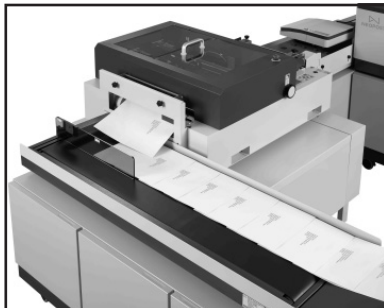

**Quadient DS-700 iQ with DEP**

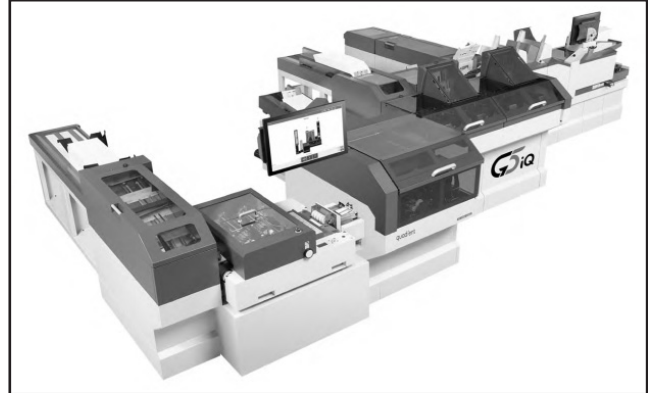

**Quadient DS-1200G5iQ**



**Quadient MACH 9DS**

tem called MACH Symphony. Create brilliant, custom envelopes with variable graphics all in the same run. It delivers the color consistency required by creative and production-oriented users. The MACH 9DS integrates seamlessly with Quadient's production-level DS folder inserters to supercharge your workflow and provide fast, dynamic, matched print finishing for inserted materials.

**CONTACT:** For more information call Quadient at 800-636-7678 or click [mail.quadient.com](http://mail.quadient.com).

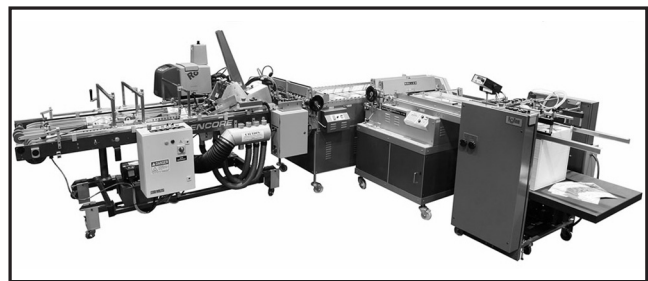

**Mailstream Direct Mail Finishing System**

## § Rollem International

**CATEGORY:** Inserter Mailing Systems

**PRODUCT:** Mailstream Direct Mail Finishing System

**COMPANY:** Rollem International, 1650 S Lewis St., Anaheim, CA 92805-6413. Phone: 800-272-4381. Web: [www.rollemusa.com/mail](http://www.rollemusa.com/mail).

**MAILSTREAM:** Print, finish, and mail 10-in-one. Mailstream, a new direct mail finishing system, converts press sheets to finished mail products while maintaining zip code or-