

Address/Barcode Printers

§ Eastman Kodak Company

CATEGORY: Address/Barcode Printers

PRODUCT: Kodak Versamark & Prosper Digital Printers

COMPANY: Eastman Kodak Company, 3000 Research Blvd, Dayton, OH 45420. Email: randy.vandagriff@kodak.com Tele: 937-259-3000. Web: www.kodak.com

KODAK VERSAMARK DS5220 AND DS5222 PRINTING SYSTEMS: The Kodak Versamark DS5220 and DS5222 Printing Systems,



KODAK Versamark DS5220

each of which is comprised of a reliable printhead and the Kodak CS150 System Controller, give you powerful solutions that help your company profit from a competitive edge in the Addressing market. With excellent registration at speeds of up to 1,000 fpm (305 mpm) and lower acquisition costs, the Kodak Versamark DS5220 and DS5222 Printing Systems allow you to quickly meet demanding customer requirements while increasing your profit per page. By leveraging the ultra-reliable and inherently flexible capabilities of the DS5220 or DS5222,

you can meet addressing needs in-house and impress customers with crisp, letter-quality character definition in a range of fonts. The DS5220 and DS5222 also easily integrate within your current equipment configuration, allowing you to simultaneously leverage existing investments and generate new business.

FEATURES: The DS5220 and DS5222 Printing Systems deliver production-proven features that help you meet high-volume requirements: 1) Boost your bottom line with an extended application range -- Ideal for higher-value applications requiring barcoding, numbering, addressing, personalization, or spot color; 2) Address exacting customer requirements: Configuration and mounting flexibility facilitates printing at any angle; 3) Easily integrate into your existing workflow: Robust and reliable controller options let you meet your specific application requirements.

KODAK VERSAMARK DS5640 AND DS5650 PRINTING SYSTEMS: The Kodak Versamark DS5640 and DS5650 Printing Systems combine high-quality printing capabilities with robust duty cycles to meet the exacting needs of discriminating customers quickly and efficiently. The DS5640 and DS5650 Printing Systems easily integrate with your existing equipment configuration, allowing you to leverage your current investments while adding new business to increase your per-page profits. With wide imprint widths at low acquisition costs, the DS5640 and DS5650 offer greater productivity and flexibility. Print width:

KODAK Prosper 7000 Turbo Press



DS5640: 4.27" (10.85 cm); DS5650: 3.41" (8.66 cm); Resolution: Up to 240 x 480 for the DS5640; up to 300 x 600 for the DS5650; Image speed: DH5640-500 model: Up to 500 fpm (152 mpm); DH5650-500 model: Up to 500 fpm (152 mpm).

KODAK VERSAMARK DS6240 PRINTING SYSTEM: THE Kodak Versamark DS6240 Printing System features specifically designed inks that make it the perfect choice for applications requiring tight security, such as lottery tickets. A wide variety of spot ink colors provides customers with a broad selection for color matching, and the printing system accommodates many software applications to assist with job layout, setup, and font selection. With flexibility built into its design and speeds of up to 1,000 fpm (305 mpm), the DS6240 allows for easy integration into existing production processes so you can maintain the high speeds your jobs demand. Ideal for higher-value applications requiring barcoding, numbering, addressing, logos, personalization, or spot color, such as direct mail solicitation, transactional printing, packaging, tags and labels, and forms.

KODAK PROSPER ULTRA 520 PRESS: The KODAK PROSPER ULTRA 520 Press delivers the quality and output you'd expect from offset—at inkjet prices. It offers: Economical consumables; Unrivalled productivity; The flexibility of variable print; Perfect for commercial printers producing direct mailers, inserts, catalogs and books. The ULTRA 520's Intelligent Print System technology constantly evaluates press operation to ensure exceptional output quality and efficient throughput. ULTRASTREAM Inkjet Technology consistently delivers print quality comparable to 200 lpi offset on uncoated, coated, glossy and silk papers – with no compromise on productivity. Expect full-color 4-over-4 perfecting output with a scalable web width of up to 21 inches (533 mm) at speeds of 500 feet per minute (152 mpm). The PROSPER ULTRA 520 is a compact unit that produces up to 62.4 million top quality pages per month. – Built with open architecture interfaces, it integrates with your existing set-up, whether that's 2-up workflow, off-line, near-line, or dedicated in-line finishing equipment.

FEATURES: When printing on glossy materials, the PROSPER ULTRA 520 Press operates at full rated speeds – unlike rival systems. Innovations in press design, drying, digital front end and imaging systems deliver unmatched reliability, flexibility and ease of use.

KODAK PROSPER 7000 TURBO PRESS: The 7000 Turbo Press delivers industry-leading speeds of 410 mpm (1,345 fpm), nearly 35% faster than its nearest competitor. When time is of the essence, the PROSPER 7000 Turbo Press's unique Turbo mode is specifically geared to handle big jobs, lightning fast: a blazing 5,523 A4s ppm. With less time needed on press for each job, the PROSPER 7000 Turbo Press enables you to take on bigger, longer, more ambitious jobs than ever before — over 200 million A4 pages per month. The PROSPER 7000 Turbo Press has been specifically designed to handle high capacity runs at super-fast speeds with minimal downtime. The KODAK PROSPER 7000 Turbo Press features a robust and reliable design optimized for productivity across a wide range of papers.

Address/Barcode Printers

FEATURES: With three optimized print modes — Quality, Performance and Turbo — the PROSPER 7000 Turbo Press allows you to fine-tune your production process to give the optimal combination of resolution and speed. For high volume applications where you need maximum quality and maximum versatility, it's the premier inkjet press solution. The PROSPER 7000 Turbo Press delivers some of the lowest print costs of any inkjet press on the market. Automated processes reduce the need for manual user input, allowing you to use your time — and your labor — more effectively.

KODAK PROSPER 6000C Press: The 6000C Press resets printing industry standards, with an unmatched combination of outstanding quality, productivity, and compelling economics. It's well suited for the demands of commercial print operations that produce direct mailers, inserts, catalogs, books and newspapers with very high ink coverage. The PROSPER 6000C Press leverages technical innovations and capabilities that are unlike those of any other press. Its Intelligent Print System technology constantly monitors and evaluates press operation to ensure exceptional output quality and efficient throughput. The PROSPER 6000C Press consistently delivers print quality that's comparable to offset—on a range of uncoated, coated, glossy and silk papers—with zero compromise on productivity. It provides full-color 4-over-4 perfecting output with a print width of up to 62.1 cm (24.45") at speeds up to 300 ppm (1,000 fpm).

FEATURES: It is one of the most cost-effective inkjet web presses available today for 8-, 12- and 16-page signatures.

CONTACT: To learn more about Kodak printers, call 937-259-3000 or visit www.kodak.com.

§ Pitney Bowes Inc.

CATEGORY: Address/Barcode Printers

PRODUCT: AddressRight Printers

COMPANY: Pitney Bowes Inc., 3001 Summer Street, Stamford, CT 06926-0700. Contact: PitneyBowes.com

ADDRESSRIGHT 100 FIXED HEAD ADDRESSING PRINTER:

The AddressRight® 100 envelope printer can print up to 22,000 #10 envelopes per hour, optimizing performance and saving costs along the way. The printer connects easily to an existing network allowing for print job processing on any computer. This system offers spot color as well as extensive fonts and graphics to make the mail piece as creative as you want it to be. The AddressRight 100 printer handles multiple media sizes up to 1/4" thick, prints in four print qualities, and works with our Envelope Design tool, which allows you to create your own design and view the envelope image on screen. It is also small enough to fit in an office or mailroom environment. Use the AddressRight 100 in tandem with one of our mail management software solutions, such as, ConnectRight™ Mailer to help you cleanse your address list ensuring delivery to your target customer and take advantage of presort discounts.



PB AddressRight 100 Envelope Printer

prints in four print qualities, and works with our Envelope Design tool, which allows you to create your own design and view the envelope image on screen. It is also small enough to fit in an office or mailroom environment. Use the AddressRight 100 in tandem with one of our mail management software solutions, such as, ConnectRight™ Mailer to help you cleanse your address list ensuring delivery to your target customer and take advantage of presort discounts.

ADDRESSRIGHT 200 FIXED HEAD ADDRESSING PRINTER:

The AddressRight® 200 envelope printer can print up to 22,000 #10 en-

velopes per hour, optimizing performance and saving costs along the way. The printer connects easily to an existing network allowing for print job processing on any computer. This system offers spot color as well as extensive fonts and graphics to make the mail piece as creative as you want it to be.

AddressRight 200

printer handles multiple media sizes up to 3/8" thick, prints in four print qualities, and works with our Envelope Design tool, which allows you to create your own design and view the envelope image on screen. It is also small enough to fit in an office or mailroom environment. Use the AddressRight 200 in tandem with one of our mail management software

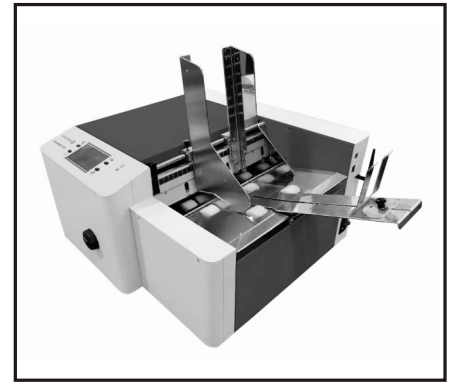

PB AddressRight 200 Envelope Printer



PB AddressRight 300 Envelope Printer

solutions, such as, ConnectRight™ Mailer to help you cleanse your address list ensuring delivery to your target customer and take advantage of pre-sort discounts.

ADDRESSRIGHT 300 FIXED HEAD ADDRESSING PRINTER:

Designed for frequent mailers, the AddressRight® 300 fixed-head envelope printer delivers optimum performance and dependability. Printing up to 26,000 #10 envelopes per hour, the AddressRight 300 can print addresses, barcodes and customized messages in one pass. The AddressRight 300 is the workhorse of address printers and can handle media up to 1/2" thick allowing for increased mail piece thickness and greater flexibility. It also works with our Envelope Design tool, which allows you to create your own design and view the envelope image on screen. While focused on productivity and performance this system offers spot color to make the mail piece as creative as you want it to be. Its fixed print heads deliver crisp precise direct-to-envelope imaging creating a professional mail piece that makes an impact.

OPTIONS: The optional Integrated Conveyor Stacker and High-Output Ink Dryer will pause when an error is detected or if the printer runs out of material or when the stacker is full – giving your operator time to resolve a problem and get production up and running again to complete the job.

CONTACT: For more about Pitney Bowes, visit PitneyBowes.com.