

# Address/Barcode Printers

## § Kirk-Rudy, Inc.

**CATEGORY:** Address/Barcode Printers

**PRODUCT:** Inkjet Printing Systems

**COMPANY:** Kirk-Rudy, Inc., 125 Lorraine Parkway, Woodstock, GA 30188. Contact: info@kirkrudy.com. Phone: 770-427-4203.

**NETJET:** Kirk-Rudy's best-selling inkjet addressing system NetJet offers the latest inkjet technology along with a new and improved user interface.

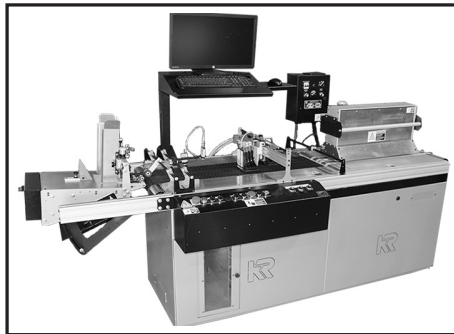

*Kirk-Rudy KR NetJet*



*Kirk-Rudy KR NetJet*



*Kirk-Rudy UltraJet v21*

with high-speed, high-quality variable color added to envelopes and web-printed pages. Produce color images, graphics, and variable data 600 dpi at 500 fpm with four 4.25" printheads. Offering a low total cost of ownership, the KRC500 KolorJet Print Module is an affordable option for adding process color versus stand-alone equipment.

**KR PHOENIX INKJET PRINT SYSTEM:** The Phoenix is a Drop on Demand variable data inkjet printing system. Utilizing one of the fastest

NetJet is designed to accommodate the needs of mailers both large and small. Even the basic configuration offers high-end features such as variable graphics, ink management and a simplified stitching process. Cartridge controls such as pen warming and calibration keep print quality

at a maximum. If additional functionality is needed, Net-Jet offers several unique options such as 1/2" of moveable print and an integrated service station that automatically caps cartridges between uses, keeping them from drying out.

**ULTRAJET V21:** Designed for maximum uptime this high-resolution inkjet system provides a versatile, cost effective solution to meet the need for variable data printing on a large variety of coated and uncoated substrates. The 2.12" print area provides consistent 600 dpi quality at high speeds. A system can be configured with up to four heads and it's small format allows easy positioning on production lines.

**KRC500 KOLORJET:** The KRC500 KolorJet is Kirk-Rudy's latest innovation in high-speed color printing. Easily add color images, graphics, and variable data to envelopes and documents for more effective communication. The KRC500 KolorJet printer offers excellent color print quality at high speeds. Increase promotional effectiveness and response rates

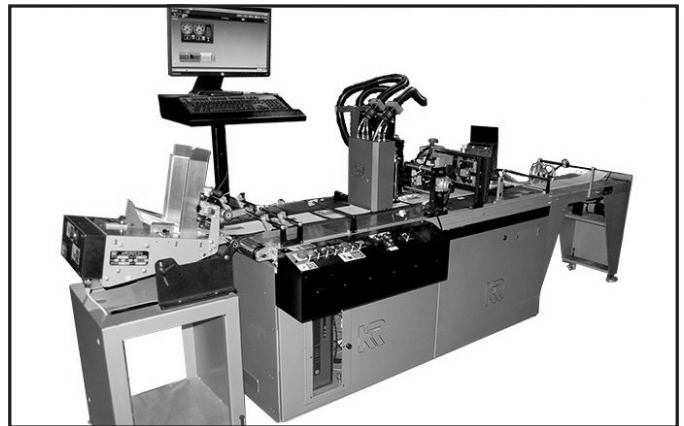

*Kirk-Rudy KR Phoenix Inkjet System*

and highest resolution inkjet print head technologies, the Phoenix meets the increasing and rigorous demands for printing variable addresses, graphics, barcodes and texts on coated and uncoated substrates. The modular design offers greater flexibility to combine the Phoenix with different technologies, such as feeding, UV curing, and camera inspection. The Phoenix offers the latest inkjet technology coupled with Kirk-Rudy's product handling systems; making it extremely versatile. With UV curable, water-based and MICR inks offered at low cost with bulk supply that comes standard, Phoenix makes operational sense.



*KRC500 Kolor Jet Printer*

**G-LINE UV INKJET PRINTERS:** Kirk-Rudy's latest UV inkjet addressing printer is available in both 2.13" (G2) and 4.25" (G4) widths. This low-cost piezo inkjet system offers high speed printing with minimal investment. With its compact design and user-friendly interface, the G-Line of printers makes it easy to upgrade current cartridge-based equipment to achieve greater ROI and huge ink cost savings. This high-resolution printer is extremely easy to operate and maintain.

**KR FIREJET 4C:**

Kirk-Rudy's most recent innovation is an all-in-one printing system that combines the heavy-duty transport they are famous for, along with the quality and reliability from Memjet and their new DuraFlex technology. This new breed of inkjet printer offers a profitable



*G-Line UV Inkjet Printers*

# Address/Barcode Printers



**Kirk-Rudy FireJet 4C Color Inkjet Printing System**

variable data forms and high quality color envelopes.

**CONTACT:** For more information, call 770-427-4203 or email [info@kirkrudy.com](mailto:info@kirkrudy.com).

## § Pitney Bowes Inc.

**CATEGORY:** Address/Barcode Printers

**PRODUCT:** AddressRight Printers

**COMPANY:** Pitney Bowes Inc., 3001 Summer Street, Stamford, CT 06926-0700. Contact: [PitneyBowes.com](http://PitneyBowes.com)

**ADDRESSRIGHT 100 FIXED HEAD ADDRESSING PRINTER:** The AddressRight® 100 envelope printer can print up to 22,000 #10 envelopes per hour, optimizing performance and saving costs along the way. The printer connects easily to an existing network allowing for print job processing on any computer. This system offers spot color as well as extensive fonts and graphics to make the mail piece as creative as you want it to be. The AddressRight 100 printer handles multiple media sizes up to 1/4" thick, prints in four print qualities, and works with our Envelope Design tool, which allows you to create your own design and view the envelope image on screen. It is also small enough to fit in an office or mailroom environment. Use the AddressRight 100 in tandem with one of our mail management software solutions, such as, ConnectRight™ Mailer to help you cleanse your address list ensuring delivery to your target customer and take advantage of presort discounts.



**PB AddressRight 100 Envelope Printer**

**ADDRESSRIGHT 200 FIXED HEAD ADDRESSING PRINTER:** The AddressRight® 200 envelope printer can print up to 22,000 #10 envelopes per hour, optimizing performance and saving costs along the way. The printer connects easily to an existing network allowing for print job processing on any computer. This system offers spot color as well as extensive fonts and graphics to make the mail piece as creative as you want it to be. The AddressRight 200 printer handles multiple media sizes up to 3/8" thick, prints in four print qualities, and works with our Envelope Design tool, which allows you to create your own design and view the envelope image on screen. It is also small enough to fit in an office or mailroom environment. Use the AddressRight 200 in tandem with one of our mail management software solutions, such as, ConnectRight™ Mailer to help you cleanse your address list ensuring delivery to your target customer and take advantage of presort discounts.

**ADDRESSRIGHT 300 FIXED HEAD ADDRESSING PRINTER:** Designed for frequent mailers, the AddressRight® 300 fixed-head envelope printer delivers optimum performance and dependability. Printing up to 26,000 #10 envelopes per hour, the AddressRight 300 can print addresses, barcodes and customized messages in one pass. The AddressRight 300 is the workhorse of address printers and can handle media up to 1/2" thick allowing for increased mail piece thickness and greater flexibility. It also works with our Envelope Design tool, which allows you to create your own design and view the envelope image on screen. While focused on productivity and performance this system offers spot color to make the mail piece as creative as you want it to be. Its fixed print heads deliver crisp precise direct-to-envelope imaging creating a professional mail piece that makes an impact.

velopes per hour, optimizing performance and saving costs along the way. The printer connects easily to an existing network allowing for print job processing on any computer. This system offers spot color as well as extensive fonts and graphics to make the mail piece as creative as you want it to be.

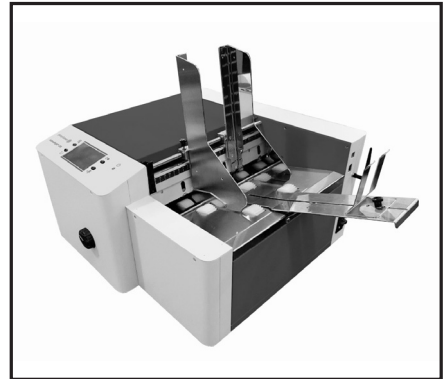

**PB AddressRight 200 Envelope Printer**

**ADDRESSRIGHT 200** printer handles multiple media sizes up to 3/8" thick, prints in four print qualities, and works with our Envelope Design tool, which allows you to create your own design and view the envelope image on screen. It is also small enough to fit in an office or mailroom environment. Use the AddressRight 200 in tandem with one of our mail management software solutions, such as, ConnectRight™ Mailer to help you cleanse your address list ensuring delivery to your target customer and take advantage of pre-sort discounts.

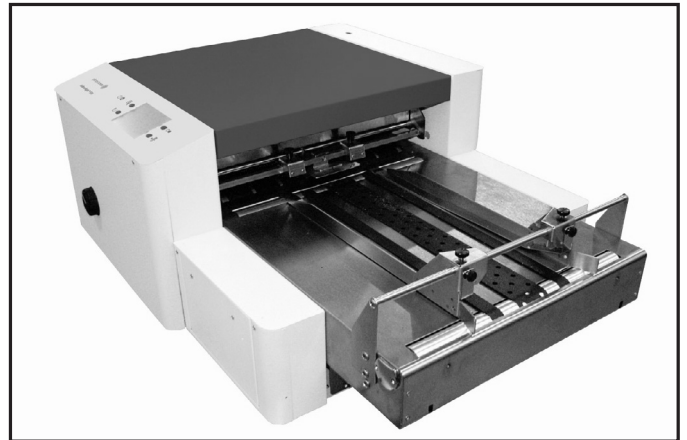

**PB AddressRight 300 Envelope Printer**

**ADDRESSRIGHT 300** solutions, such as, ConnectRight™ Mailer to help you cleanse your address list ensuring delivery to your target customer and take advantage of pre-sort discounts.

**ADDRESSRIGHT 300 FIXED HEAD ADDRESSING PRINTER:** Designed for frequent mailers, the AddressRight® 300 fixed-head envelope printer delivers optimum performance and dependability. Printing up to 26,000 #10 envelopes per hour, the AddressRight 300 can print addresses, barcodes and customized messages in one pass. The AddressRight 300 is the workhorse of address printers and can handle media up to 1/2" thick allowing for increased mail piece thickness and greater flexibility. It also works with our Envelope Design tool, which allows you to create your own design and view the envelope image on screen. While focused on productivity and performance this system offers spot color to make the mail piece as creative as you want it to be. Its fixed print heads deliver crisp precise direct-to-envelope imaging creating a professional mail piece that makes an impact.

**OPTIONS:** The optional Integrated Conveyor Stacker and High-Output Ink Dryer will pause when an error is detected or if the printer runs out of material or when the stacker is full – giving your operator time to resolve a problem and get production up and running again to complete the job.

**CONTACT:** For more about Pitney Bowes, visit [PitneyBowes.com](http://PitneyBowes.com).