

Inserters Mailing Systems

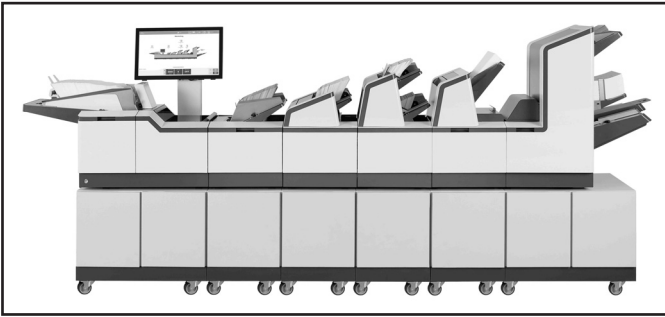

Quadiant DS-180i

financial statements. The system uses Quadiant's proprietary and robust IMOS operating system and, as a result, has the features and technology to meet the demands of your business with ease. Due to its ability to handle a superior document packet thickness of 1/4", the DS-180i allows you to process a wide variety of mail for invoicing, monthly statements, marketing campaigns and virtually all of your organizations mail requirements. The system's large color graphic interface reaches new heights in user friendliness and workflow programming. Enhance the productivity of your mail center with the DS-180i Performance Package. It has earned the designation of "Performance Package" for its increased processing speed, envelope capacity, enhanced sealing capacity and productivity.

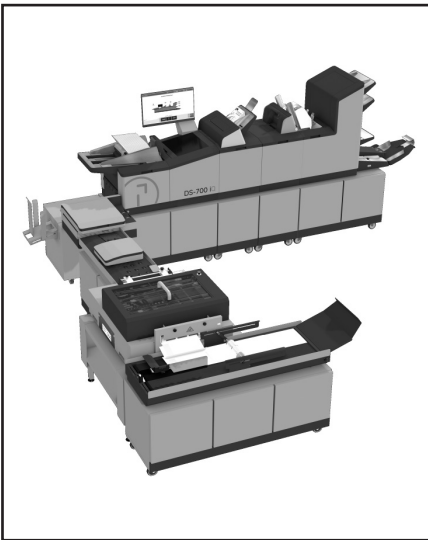

Quadiant DS-700 iQ

The DS-180i can be customized to process your applications with up to 8 system modules and 17 feeders.

DS-700 iQ: The new standard in mail production, the DS-700 iQ is a powerful solution that has an advanced modular design that will grow with mailer needs. Quadiant engineers took a hard look at mail centers around the world and then designed this advanced folding and inserting system which can be customized to meet the workflow requirements of the widest range of mailing applications, including flats. The practical speed is up to 7,000 envelopes per hour and can handle monthly volumes up to 300,000. Users will find practical innovation everywhere you look. Powerful and intuitive, the DS-700 iQ has unlimited job memory; auto-setup, which eliminates hours of manual adjustments; a unique scanning module reads almost any type of document coding; landscape insertion, offering higher speeds and lower envelope costs; and a 23" color touch screen.

Quadiant DS-700 iQ with DEP

The DS-700 iQ meets the workflow demands of almost every mailing application – from direct marketing to highly sensitive mailings including medical billing and patient information, to payroll and personal financial statements. Our inline secure personalization module provides security and the ability to meet privacy compliance requirements. For marketers, it provides unprecedented personalization opportunities. The DS-700 iQ fully integrated direct impression envelope printing solution allows you to personalize envelopes as part of the mail assembly process. This eliminates

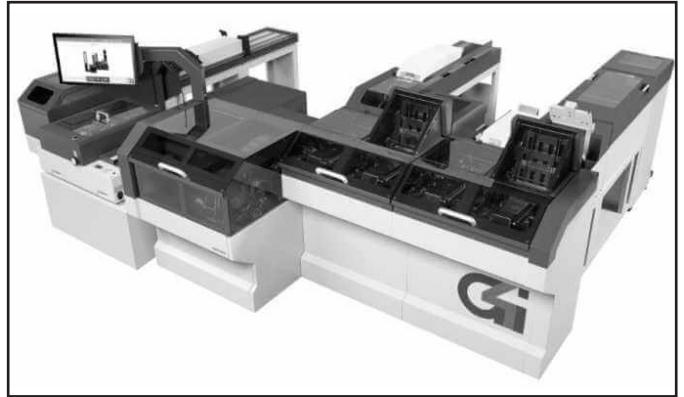

Quadiant DS-1200G4i

the need for window envelopes and insures the privacy of your important customer information. Once the documents have been folded and inserted, the secure system prints the matched name and address on the closed face envelope. This process ensures integrity and security, allowing sensitive information to remain confidential.

DS-1200G4i: The DS-1200G4i is designed to operate at the highest practical speed and efficiency – up to 12,000 envelopes per hour – streamlining the entire mailing process, from input to throughput to output, even during peak or rush times. The high-capacity sheet feeders, insert stations, envelope feeder, and updated vertical envelope output stacker enable users to maintain the highest level of operational productivity even for the most demanding mail processing job.

CONTACT: For more information call Quadiant at 800-636-7678 or click mail.quadiant.com.

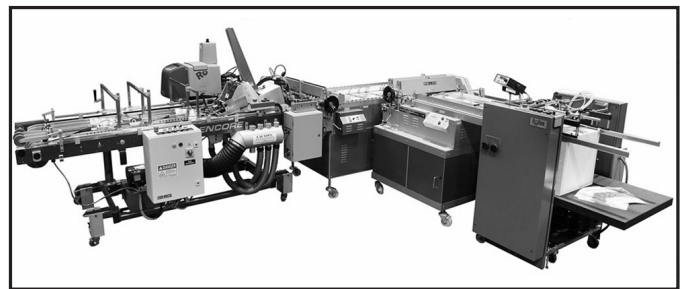

Mailstream Direct Mail Finishing System

§ Rollem International

CATEGORY: Inserter Mailing Systems

PRODUCT: Mailstream Direct Mail Finishing System

COMPANY: Rollem International, 1650 S Lewis St., Anaheim, CA 92805-6413. Phone: 800-272-4381. Web: www.rollemusa.com/mail.

MAILSTREAM: Print, finish, and mail 10-in-one. Mailstream, a new direct mail finishing system, converts press sheets to finished mail prod-

Inserters Feeders/Accessories

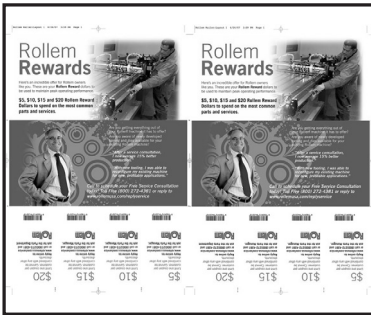

Two-Up Trifold Mailer

for wafer seals. In-line and near-Line configurations available.

CONTACT: For more information, call 800-272-4381 or click www.rollemusa.com/mail.

§ BOWE SYSTEC North America Inc.

CATEGORY: Inserter Feeders/Accessories

PRODUCT: A Line of Camera Solutions & Software

COMPANY: BOWE SYSTEC North America Inc., 8480 Honeycutt Rd, Ste 200, Raleigh, NC 27615-2260, www.bowesystecinc.com.

TOPCAM CUBE: The topSenso product family topCam offers premium camera solutions for virtually any application. In the mailroom, in the pharmaceutical, food or cosmetics industries – this area scan camera is an economical solution for nearly every production procedure operated and monitored using codes. The topCam Cube-series offers a compact design and comes with the finest high-end technology, available in three resolutions. From the high-density version with reading rates of up to 100 scans per second to the low-density solution for larger scan areas, the topCam Cube family offers the perfect camera specifications for customized solutions and applications. topCam Cube enables secure code identification and full documentation at high speeds with up to 100 readings per second and supports all standard codes (1D bar-code, 2D code, OMR, pharmaceutical code), plain writing, OCR/OCV, as well as addresses and labels. It has a high depth of field (+/- 20 mm) and a high resolution mega chip sensor technology. topCam Cube provides flexible solutions with high, standard and low density versions and module sizes from 0.15 mm.



topCam Cube

ucts while maintaining zip code order. Apply 10 processes in one operation including hot, cold and fugitive glue; tear-off coupons; tip-on cards; trimming, slitting, scoring, pattern-perforations, and scratch-off labels. Mail integrity is maintained creating folded, glued products ready for delivery to mail bins. Glue closures meet USPS requirements and eliminate the need

ucts while maintaining zip code order. Apply 10 processes in one operation including hot, cold and fugitive glue; tear-off coupons; tip-on cards; trimming, slitting, scoring, pattern-perforations, and scratch-off labels. Mail integrity is maintained creating folded, glued products ready for delivery to mail bins. Glue closures meet USPS requirements and eliminate the need

TOPCAM EAGLE: The topSenso product family topCam offers premium camera solutions for all kinds of applications. Areas can cameras are typically used in modern printing and mail processing centers, as well as in the pharmaceutical, food and cosmetics industries. They are in high demand wherever high definition image capturing at high speed and precision is required. Products in the topCam Eagle-series come with a separate optical head for use in the most hard-to-reach areas. From the high-density version with scan rates of up to 70 scans per second to the low-density solution for larger scan areas, the topCam Eagle product family always offers the perfect camera solution. All standard codes are supported (1D bar-code, 2Dcode, OMR, pharmaceutical code), as well as plain writing, OCR/OCV, addresses and labels. TopCam Eagle provides a flexible solutions with high, standard and low density versions and module sizes from 0.15 mm and comes with a high depth of field (+/- 20 mm) and a high resolution mega chip sensor technology. Changeover times can be reduced and productivity increased thanks to a quick set-up via a simple user interface.



topCam Eagle

ORBITER: In this “Age of Smartphones” we have become used to easily operable and clearly laid out apps. For exactly that reason BOWE SYSTEC has conceived a solution making the advantages of modern software available in an industrial environment — Orbiter. To an unprecedented degree Orbiter makes all individual programs (apps) easily accessible which are involved in the workflow of the complete mailroom. Orbiter offers all apps in a marketplace not restricted to BOWE SYSTEC apps but also containing software provided by partner companies: Orbiter Shop. Whatever is needed for the workflow is chosen there and made available for use. Structure and layout of the app icons in the navigation bar can be fully customized. This smart navigation solution allows the arrangement in any order or structure making complex things easy and comprehensible. Best of all: Orbiter is free of charge. Orbiter is a state-of-the-art navigation tool for organizing and structuring the whole workflow in the mailroom. Customers decide for themselves what the structure should look like. Orbiter makes the navigation of all mailroom apps possible – from pre-production and order management to machine control. This finally ends the change from one program to the next from different manufacturers, which is typical in today’s environment. Orbiter Shop is the marketplace where all apps are available and presented grouped into categories. Customers can individually combine apps according to their workflow. The Orbiter Shop includes BOWE SYSTEC

ucts while maintaining zip code order. Apply 10 processes in one operation including hot, cold and fugitive glue; tear-off coupons; tip-on cards; trimming, slitting, scoring, pattern-perforations, and scratch-off labels. Mail integrity is maintained creating folded, glued products ready for delivery to mail bins. Glue closures meet USPS requirements and eliminate the need

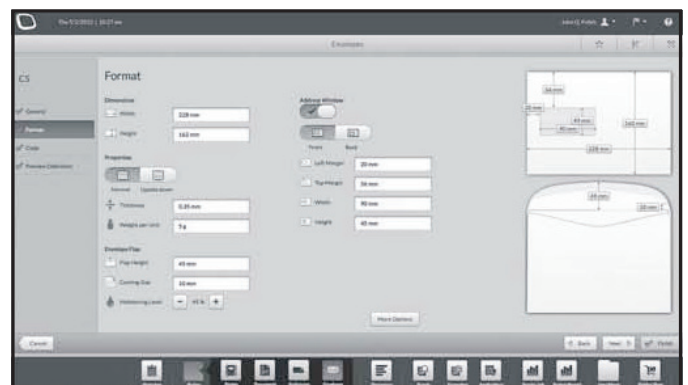

BOWE Cockpit Recipe

Your mail industry authority is just a click away.
www.mailomg.com