

Inserters Mailing Systems

pages are being folded and inserted, but also which specific pages are intended for each individual customer, giving you the capability to recreate a mailing event at a personalized recipient level.

CONTACT: For more information call 877-682-7687 or visit Pitney Bowes at PitneyBowes.com.

§ QUADIENT

CATEGORY: Inserter Mailing Systems

PRODUCT: Document Systems

COMPANY: Quadient, 478 Wheelers Farms Rd., Milford, CT 06461. Phone: 800-636-7678.

DS-40i: The DS-40i allows offices and departmental organizations with daily folding and inserting applications to benefit from the same advanced technology that provides the precision and reliability associated with large volume mailing systems. The DS-40i is designed to handle a monthly envelope inserting volume of 5,000. It has a simple and intuitive user interface enabling all personnel to operate the system without being trained and with no need for a dedicated operator. This automated system fits perfectly on a desk and ensures users do not have to waste time and money to hand-fold and insert their day-to-day outgoing mailing, enabling on-demand inserting. The DS-40i has a simple hand-feeding option, which allows users to put the paper in its feeder every time a set of documents is read to be sent.



Quadient DS-40i

DS-64i: The compact design, intuitive 7" color touchscreen interface and overall ease-of-use of the DS-64i make it the ideal choice for any busi-



Quadient DS-64i

ness environment. At speeds of up to 2,000 envelopes per hour/2,500 with performance package, the DS-64i folding inserting system has the technology needed to efficiently prepare your business mailings. It automates the processing of checks, multi-page invoices, letters, legal-size documents, inserts and business reply envelopes. The CIS reads a full range of barcodes and optical marks printed on your documents, allowing securely processing of variable page documents

DS-77 iQ: The DS-77 iQ folder inserter system is the ideal productivity tool for any office or mailroom environment, thanks to its unique low level noise and compact footprint. High Productivity: processing speed of up to 3,800 inserts per hour, high-capacity document feeders holding up to 725 sheets of 20 lb. paper, standard high-capacity vertical stacker holding up to 500 envelopes. High Mailing Application Flexibility and Sup-



Quadient DS-77 iQ

port: increased folding capacity; support for barcode reading in personalizing transactional and marketing mail. New Standard in Ease of Use: new graphical color touch screen designed for easy setup, semi-automatic envelope separation setup; automatic sealing liquid level detection and automated sealing capability. The DS-77 iQ can process a wide variety of mail pieces for direct marketing efforts, campaigns, invoicing, monthly statements and virtually any other application companies can or will do in the future.

DS-85i: Ideal for mail centers maintaining an outgoing speed of 4,000 filled envelopes per hour, the DS-85i provides enhanced ease-of-use, increasing customers' mailroom efficiency and productivity, while reducing postal costs. The DS-85i's unique full-color touch screen can be reversed to allow operation from any angle. Quadient's "Load 'n Go" feature further simplifies the mailing process, as users need only to load documents and envelopes into the machine and then press the "Go" button. The DS-85i automatically adjusts settings, saving them to memory for instant recall during future mailings. In addition, the folder inserter's operation requires the use of only three buttons, allowing anyone to easily run the machine. Add an optional barcode reading solution to easily apply barcodes to existing documents to ensure each recipient receives their correct documents.

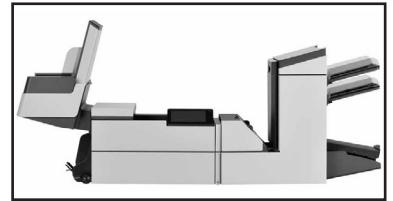

Quadient DS-85i

DS-95i: The DS-95i is the ultimate mid-range solutions for your inserting needs. The completely new graphical user interface with full color icons walk the operator through set up in just three steps – and that's in manual mode! Remote Assistance provides your Quadient customer service team with immediate access to your system over the internet to help maximize your productivity.

DS-95i includes a color graphical user interface with super bright touch screen; Remote Assist – connect to your service tech over the internet; flexFeed® technology gives you the ability to handle any document size or paper type; With powerFold®, you can crisply and silently fold up to 10 pages in single fold and 8 pages in tri-fold; Add optional OMR, 1D or 2D Barcode or Optical Character Recognition to ensure each recipient gets their correct documents; Configurable from two to seven stations and totally upgradeable; High capacity carrier envelope hopper holds 500 envelopes with optional 1000 envelope capacity; High capacity document feeder holds 725 sheets; Versafeeder holds up to 500 BRE envelopes; Feeder linking allows for continuous document feeding of up to 3,125 sheets.

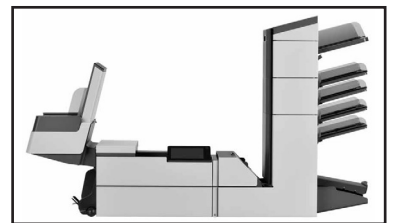

Quadient DS-95i

DS-180i: The DS-180i folding inserting systems makes operational excellence a reality for your mail processing needs. Its modular design supports the widest range of mailing applications – from direct mail campaigns to highly sensitive mailings such as medical billing, payroll and fi-

Inserters Mailing Systems

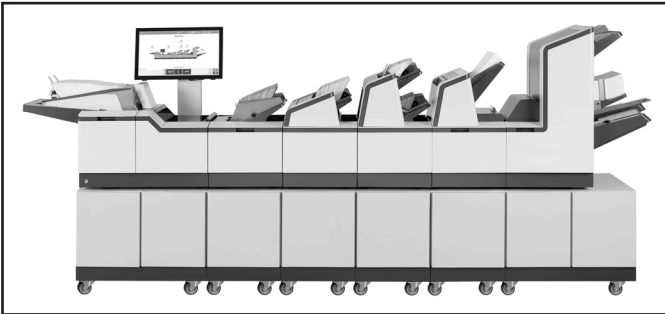

Quadiant DS-180i

financial statements. The system uses Quadiant's proprietary and robust IMOS operating system and, as a result, has the features and technology to meet the demands of your business with ease. Due to its ability to handle a superior document packet thickness of 1/4", the DS-180i allows you to process a wide variety of mail for invoicing, monthly statements, marketing campaigns and virtually all of your organizations mail requirements. The system's large color graphic interface reaches new heights in user friendliness and workflow programming. Enhance the productivity of your mail center with the DS-180i Performance Package. It has earned the designation of "Performance Package" for its increased processing speed, envelope capacity, enhanced sealing capacity and productivity.

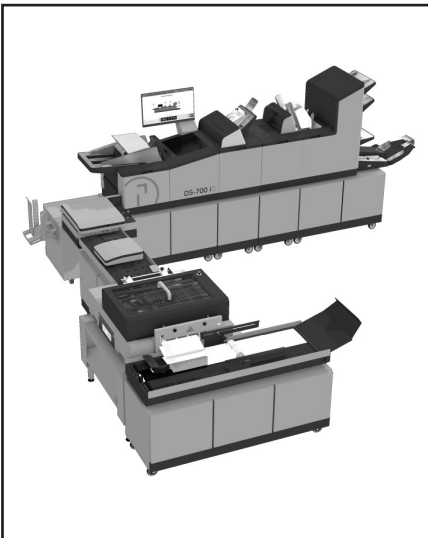

Quadiant DS-700 iQ

The DS-180i can be customized to process your applications with up to 8 system modules and 17 feeders.

DS-700 iQ: The new standard in mail production, the DS-700 iQ is a powerful solution that has an advanced modular design that will grow with mailer needs. Quadiant engineers took a hard look at mail centers around the world and then designed this advanced folding and inserting system which can be customized to meet the workflow requirements of the widest range of mailing applications, including flats. The practical speed is up to 7,000 envelopes per hour and can handle monthly volumes up to 300,000. Users will find practical innovation everywhere you look. Powerful and intuitive, the DS-700 iQ has unlimited job memory; auto-setup, which eliminates hours of manual adjustments; a unique scanning module reads almost any type of document coding; landscape insertion, offering higher speeds and lower envelope costs; and a 23" color touch screen.

Quadiant DS-700 iQ with DEP

The DS-700 iQ meets the workflow demands of almost every mailing application – from direct marketing to highly sensitive mailings including medical billing and patient information, to payroll and personal financial statements. Our inline secure personalization module provides security and the ability to meet privacy compliance requirements. For marketers, it provides unprecedented personalization opportunities. The DS-700 iQ fully integrated direct impression envelope printing solution allows you to personalize envelopes as part of the mail assembly process. This eliminates

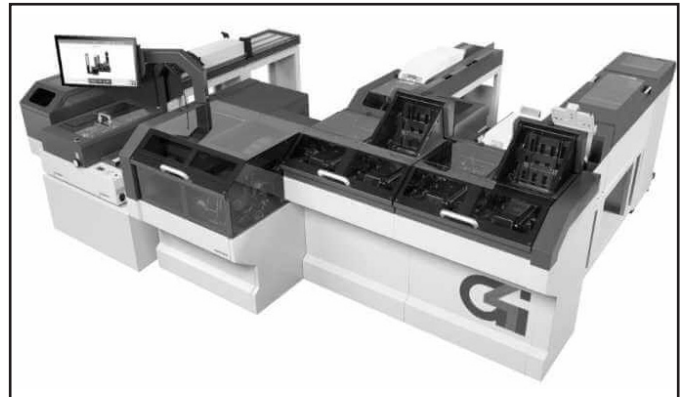

Quadiant DS-1200G4i

the need for window envelopes and insures the privacy of your important customer information. Once the documents have been folded and inserted, the secure system prints the matched name and address on the closed face envelope. This process ensures integrity and security, allowing sensitive information to remain confidential.

DS-1200G4i: The DS-1200G4i is designed to operate at the highest practical speed and efficiency – up to 12,000 envelopes per hour – streamlining the entire mailing process, from input to throughput to output, even during peak or rush times. The high-capacity sheet feeders, insert stations, envelope feeder, and updated vertical envelope output stacker enable users to maintain the highest level of operational productivity even for the most demanding mail processing job.

CONTACT: For more information call Quadiant at 800-636-7678 or click mail.quadiant.com.

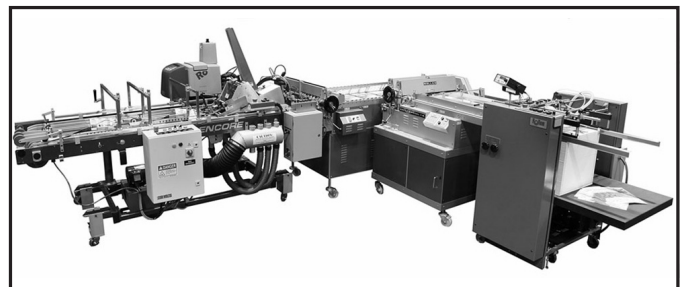

Mailstream Direct Mail Finishing System

§ Rollem International

CATEGORY: Inserters Mailing Systems

PRODUCT: Mailstream Direct Mail Finishing System

COMPANY: Rollem International, 1650 S Lewis St., Anaheim, CA 92805-6413. Phone: 800-272-4381. Web: www.rollemusa.com/mail.

MAILSTREAM: Print, finish, and mail 10-in-one. Mailstream, a new direct mail finishing system, converts press sheets to finished mail prod-